

Distribution System Grounding Fundamentals

Edward S. Thomas, PE - Senior Member
Richard A. Barber - Member
Utility Electrical Consultants, PC
Raleigh, NC 27601

John B. Dagenhart, PE - Senior Member
Allen L. Clapp, PE, PLS - Senior Member
Clapp Research Associates
Raleigh, NC 27612

Abstract - The most common medium voltage electric distribution system in the United States is multigrounded wye using a common neutral for both primary and secondary systems. The effective interconnection of the multigrounded wye neutral conductor with the earth ground reference is very important for safe and effective operation of these systems. Areas of concern include:

- Public Safety
- Operating Personnel Safety
- System Reliability
- Power Quality
- Customer Surge Protection

This paper is intended to address how grounding system effectiveness affects each of these goals.

Key Words - Grounding, Earthing, Safety, Surge Protection, NESC, Neutral-to-Earth Voltage, Ground Currents, Stray Voltage.

I. INTRODUCTION

This paper is intended to give an overview of the various relationships between neutral currents, ground currents, electrode impedances and voltage potentials that are encountered in the grounding of multigrounded wye distribution systems. This system configuration is the most commonly used configuration among U.S. domestic utilities. Voltages range from 4.16/2.4 kV to 34.5/19.9 kV. The most common system voltages are 15 kV and 25 kV class systems with nominal operating voltages on rural systems generally being 12.47/7.2 kV and 24.9/14.4 kV. The paper is intended to review the relationships which might be encountered due to system grounding and provide an overview of common installations and their relative effectiveness.

The NESC requires multigrounded distribution system neutrals to be effectively grounded (Rule 96C). The definition of *effectively grounded* is as follows:

Effectively Grounded. Intentionally connected to earth through a ground connection or connections of sufficiently low impedance and having sufficient current-carrying capacity to limit the buildup of voltages to levels below that which may result in undue hazard to persons or to connected equipment.

Effective grounding, or earthing, of the distribution system neutral is necessary to achieve several objectives, the most important of which is the safety of the public and utility personnel. The effectiveness of the grounding system also affects system reliability, power quality, and the longevity of both utility and customer equipment. Effective grounding and bonding reduces voltages between adjacent grounded facilities within utility and public/customer installations.

For all of these objectives, the general method to achieve maximum effectiveness of the utility grounding system is to establish the best practical connection between the neutral conductor and the earth. Decreasing the resistance in this connection reduces both:

- the effect of lightning discharges on or near utility or customer facilities, and
- the effect of neutral-to-earth (NTE) voltages that may exist between the neutral and earth.

A low neutral-to-earth impedance is particularly important when the distribution system neutral is connected to metallic objects that are accessible to the public. These objects include guy wires, pole grounds and the customer-owned wiring and plumbing within a residence or other building. If these classes of metallic objects are not interconnected to the distribution system neutral, there could be a strong local voltage difference between these objects, either on the utility facilities or within customer premises. Bonding of grounded conductors of circuits entering customer facilities is required to assure the safety and reliability of customer equipment.

The importance of effective grounding and bonding is recognized by both the National Electrical Safety Code (NESC) (ANSI C2) and the National Electrical Code (NFPA 70). Both codes require interconnection of the power, telephone, CATV, and customer grounding conductors at the served installation, in order to limit voltage potentials that may be hazardous to personnel or equipment.

Another area where interconnection of system neutrals is important is with the other utilities, principally communication utilities, that occupy joint use structures and enter the same customer premises as the electric system neutral. In

order for joint-use occupants to minimize utility structure size, adjacent grounded facilities must be bonded. Otherwise, workers could be exposed to steady state and/or transient voltages between metallic objects within close proximity to each other. Of course, when bonding interconnects the electric utility distribution system neutral with messengers or cable shields of communication utilities, any NTE voltages on the distribution system neutral are imposed on the communication utilities. This results in communications utility messengers and cable shields sharing the flow of neutral currents. Consequently, it is important for the electric utility to be effectively grounded to minimize the existence of these currents.

II. NEUTRAL-TO-EARTH IMPEDANCE

The effective impedance of a neutral-to-earth connection is significantly affected by the area and shape of the electrode, the depth of the electrode, and the resistivity of the earth surrounding the electrode.

As the surface area of the electrode increases, current density across the surface decreases. Since electrical losses in the form of heating are a function of the square of the current flow (I^2R), a larger surface area (a) produces less heating (drying) of the earth around the electrode for the same overall current flowing across the electrode and, thus, (b) allows more current to flow through the earth surrounding the electrode for a longer period of time. Just as an incandescent bulb (a high-intensity point source of light) is more difficult to view with the eye than a fluorescent bulb with the same total light output (a low-intensity, linear light source with more surface area), a linear ground electrode, such as a rod or strip, is often more effective than a plate or coiled electrode, because the former have access to more earth with which to dissipate the energy.

As soil depth increases, so generally does both moisture and pressure, both of which increase soil conductivity and reduce resistance of the electrode/soil interface.

The resistivity of the soil significantly affects the ability of an electrode to transfer current to the earth from utility system electrodes. A value of 100 Ω -m (ohm-meters) is commonly used to represent typical earth resistivity around utility ground electrodes. An earth resistivity of 30 Ω -m (3000 Ω -cm) or less is considered by the NESC to be low resistivity (NESC Committee comments in 15 August 1973 Draft of NESC Part 2 1977 Edition). However, the resistivity of dry sands and gravels can be 1000-3000 Ω -m or even higher. Therefore, the resistance of an electrode in such soil can be more than an order of magnitude (10 times) higher than shown by a typical calculation assuming 100 Ω -m. The value of soil resistivity must be known with a reasonable degree of certainty before any meaningful calculations can be made.

III. TYPES OF GROUNDING ELECTRODES

The electric utility distribution system, due to its versatility and interconnection with other utilities, offers a wide variety of grounding electrode categories. It is important to understand the properties and function of each type of grounding electrode.

A. Substation Grounds

The ground mat at the substation serving as a source for the distribution circuit is one of the paths for neutral current to return to the transformer neutral connection. While distribution system neutral grounds near the substation may also pick up some of the earth return current, the substation ground mat is generally the principal route for earth currents. This is due to the relatively low resistance of this element when compared with the resistance of other ground connections in the vicinity of the substation. The resistance of substation ground mat should always be less than 10 ohms. Typical ground system impedances for small substations with lower fault currents generally fall between 2 and 7 ohms. With good design, mats which cover large areas may achieve impedances of less than one ohm. The higher the available fault current or the net neutral current in the station, the greater will be the need for an effective, low-impedance ground system. See IEEE Standard 80-2000 for methods to limit touch, step and mesh potentials.

B. Distribution System Neutral Grounds

NESC Rules 96C and 97C require that a neutral on multigrounded wye distribution systems have a minimum of four ground connections in each mile. The four-grounds-per-mile rule also applies to URD cables with insulating jackets. Treatment of these underground cable grounding electrodes should be the same as with the distribution system neutral grounds.

Distribution system neutral grounds are generally the same configuration as equipment grounds and typically have the same resistance characteristics.

C. Equipment Grounding Electrodes

Equipment grounding electrodes are normally driven ground rods. The requirements for equipment grounding electrodes are found in NESC Rule 94. These are installed for each distribution transformer or lightning arrester installation. The NESC requires a minimum electrode nominal diameter of 1/2" or 5/8", depending upon material, and a minimum buried length of 8'. This resistance achieved with a 5/8" diameter 8 ft long rod is approximately 40 Ω in 100 Ω -m soil or approximately 12 Ω in 30 Ω -m soil. Actual installed resistance will vary widely depending upon soil resistivity. These ground rod electrodes may be used to meet both the transformer grounding requirements and the

four-grounds-per-mile requirement of NESC Rules 96C and 97C.

D. Pole Grounds

On some systems, it is common to install a pole ground at each pole to (a) protect the pole from lightning until the conductors are installed and (b) help decrease NTE impedance after the neutral is installed. These pole grounds generally consist of a grounding conductor installed from the neutral of the distribution system down the pole to the butt. In some cases the pole ground will extend to the top of the pole. The butt end of the pole ground is commonly terminated in a butt wrap on the last two feet of the pole or a butt coil on the base of the pole. In some cases the pole ground is attached to a butt plate (in lieu of a butt coil) which provides a plate electrode approximately the diameter of the pole butt.

The 60 Hz resistance of pole grounds is generally high. This is due to the small diameter of the conductor, the shading effect of the non-conductive pole and the relatively poor contact of the conductor with the surrounding soil (i.e., backfill). On some types of poles, the leaching of the preservative may form a high resistance film between the grounding conductor and the surrounding earth. The pole butt plates, if they do not develop an insulating film, may have a 60 Hz resistance of approximately 150 ohms in 100 ohm-meter soil. These butt-wrap and butt-plate/coil pole ground electrodes are not as effective as a driven ground rod and may not be used as the sole electrode at a transformer/arrester location (NESC Rule 94B4a). However, if installed in an area with low soil resistivity (30 Ω -m or less), one such electrode may be considered as half of an electrode for purposes of meeting the four-grounds-per-mile requirements of NESC Rules 96C and 97C.

E. Customer Grounds

National Electrical Code (NFPA 70) Article 250.52 requires that all customers receiving electric service attach a grounding conductor from the service entrance equipment to an existing electrode or a made electrode installed for the purpose. The minimum dimensions for ground rod electrodes are 5/8" x 8'. If a single electrode does not have a resistance of less than 25 ohms, the installation of a second electrode is required. Experience indicates that the average electrode resistance achieved by the customer is greater than 25 ohms, unless soil resistivity is significantly less than 100 Ω -m (i.e., 60 Ω -m) or a multiple-electrode grounding electrode system is used. Another factor causing high customer ground resistance is the practice of driving rods immediately adjacent to building foundations where soil moisture content (and thus conductivity) may be lower.

F. URD Cable with Bare Concentric Neutral and Counterpoise Conductors in Direct Contact with Earth

For purposes of grounding calculations, the concentric neutral on older underground residential distribution cables with bare neutral wires in direct contact with earth (not in conduit) can be treated as an equivalent counterpoise conductor. NESC Rule 94B5 allows 100 ft of bare concentric neutral cable (or cable with a semiconducting jacket of 100 Ω -m or less radial resistivity) to be considered as equivalent to a ground rod. When placed in soil of 100 Ω -m resistivity, the neutral-to-earth impedance is approximately 6 Ω . The 60 Hz impedance of a counterpoise can be calculated using Reference B7 (Equations 5.13 and 5.14) and Reference C4 (pages 307-312). A reasonable estimate for a 250-foot length of 15 kV unjacketed cable with a full concentric neutral would be between 2.0 ohms and 2.6 ohms at 60 Hz in 100 ohm-meter soil. At underground riser poles this resistance can be considered as being connected in parallel with the ground rod normally installed at that location. When depending on a counterpoise as the principal electrode at a location, careful consideration should be given to seasonal variations in soil resistivity at the counterpoise burial depth.

G. Metallic Water Distribution Systems

Article 250.104 of the National Electrical Code requires that all customer neutrals be interconnected (bonded) with metallic water piping within the customer's premises. The purpose of this requirement is to eliminate any voltage differential between these systems and, thereby, minimize the opportunity for shock to customers in contact with both water piping and an electrical appliance connected to the distribution system neutral. By virtue of this bonding, any neutral voltage existing on the distribution system can impose a current onto the customer service. This current is distributed to earth through the customer piping and/or any interconnected municipal water supply piping. Of course, the use of plastic pipe in the customer's water service or in the community water distribution systems limits the flow of earth return current to those interconnected metallic piping sections which are in contact with earth.

If the customer has a 100 foot section of 3/4" copper line between the water meter and house, resistance of this line section will be approximately 5.8 ohms and will be in a parallel path with other distribution system neutral earth connections. If the copper service line is connected into 1000 feet of 6 inch bare metallic water distribution main, the resistance to earth of that pipe section would be approximately 0.6 ohms in 100 Ω -m earth. It is apparent

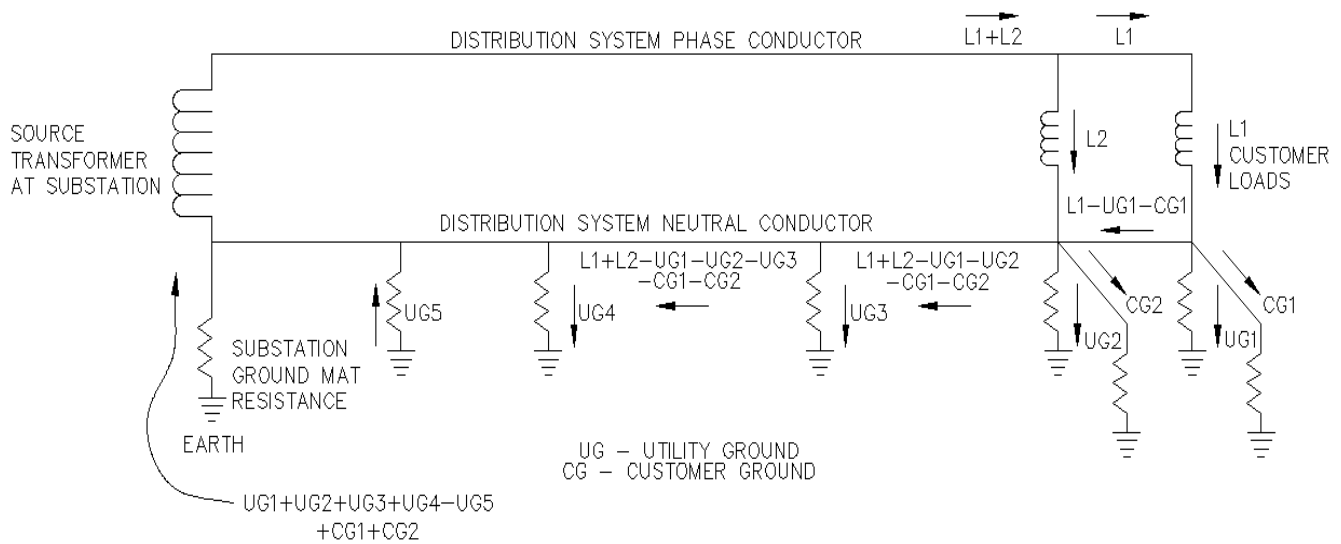

FIGURE 1 – SIMPLIFIED MULTIGROUNDED WYE DISTRIBUTION SYSTEM PRIMARY NEUTRAL CIRCUIT

that some sections of community water distribution systems can be very effective ground paths for neutral return current, even if the piping is not continuous back to the distribution substation which is the source of the distribution circuit. By being connected in parallel with the customer distribution service entrance ground, any existing water system grounds will greatly reduce the effective ground electrode resistance of the average customer service.

IV. NEUTRAL-TO-EARTH VOLTAGE SOURCES

The voltage between a neutral and nearby earth can originate with a variety of sources and can take at least two distinct forms. The area of most common concern from a public safety standpoint is the 60 Hz voltage that may exist between objects connected to the neutral and earth. This is particularly important as the distance increases between the bonded object and an effective grounding electrode. Both the magnitude and duration of the NTE voltage are important factors.

A second type of voltage that will appear between neutral and earth is the extremely short duration transient occurring when lightning is dissipated into the earth, either through a direct strike to the utility neutral or when surge protection equipment passes the lightning stroke charge from energized conductors to the neutral and its interconnected grounding electrodes. This typically occurs as a high frequency, steep wavefront event, such as a 1/2 x 50 micro-second or longer waveform.

A. Steady-State 60 Hz Voltage

Figure 1 shows a simplified multigrounded wye distribution system with multiple ground connections on the primary neutral and multiple customer loads. Magnitudes and directions of current flow shown in Figure 1 are simplified for discussion purposes and may vary greatly depending on local conditions. The following discussions will further simplify this circuit in order to show the effect of different conditions.

The predominant source of NTE voltage is the steady-state condition that is created by voltage drop in the system neutral conductor as current passes through this conductor. To use an extreme case as an example, consider a long, single-phase line where the neutral conductor has no grounding. See Figure 2, Scenario 1. All of the load current must pass through the neutral conductor. This will generate in the neutral conductor a voltage drop equal to that in a phase conductor of the same size and composition. As an example, if a two-mile long 1/0 ACSR single-phase line carries 1 ampere to a load at the end of the line and the neutral is effectively grounded at its source, the voltage drop in each conductor of this line would be approximately 1.37 volts. Given the condition of the effective grounding at the source of the tap, the voltage between the neutral conductor and earth at the load point would be 1.37 volts.

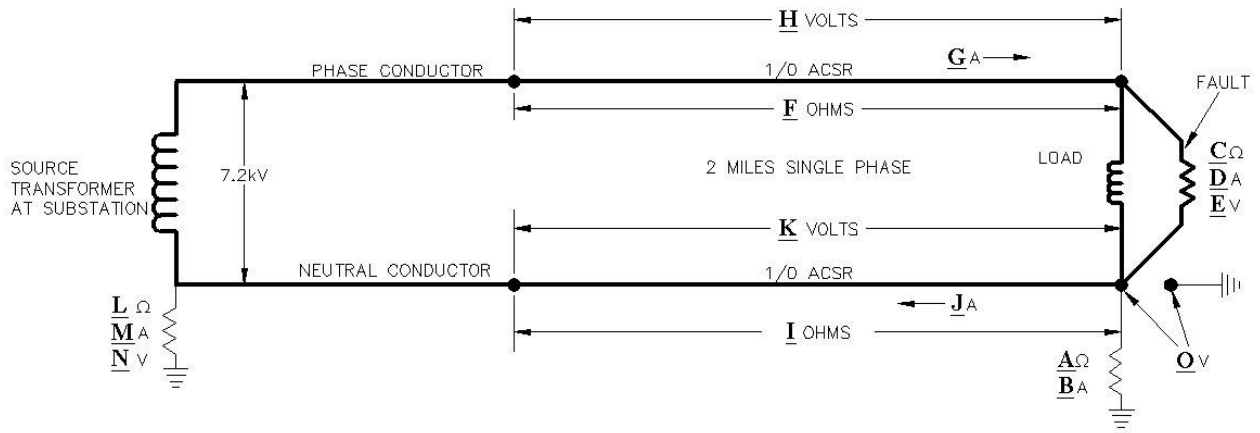

FIGURE 2 – HYPOTHETICAL CIRCUIT FOR EXAMPLE CASE

DATA FOR FIGURE 2 CIRCUIT

| POINT | UNIT | 1 AMP LOAD NO GROUND AT LOAD | 1 AMP LOAD 1Ω GROUND AT LOAD | FAULT NO GROUND AT LOAD | FAULT 1Ω GROUND AT LOAD |
|-------|-------|------------------------------------|------------------------------------|-------------------------------|-------------------------------|
| | | SCENARIO 1 | SCENARIO 2 | SCENARIO 3 | SCENARIO 4 |
| A | OHMS | ∞ | 1 | ∞ | 1 |
| B | AMPS | 0 | 0.41 | 0 | 1341 |
| C | OHMS | ∞ | ∞ | 0 | 0 |
| D | AMPS | 0 | 0 | 2628 | 3298 |
| E | VOLTS | 7197 | 7198 | 0 | 0 |
| F | OHMS | 1.37 | 1.37 | 1.37 | 1.37 |
| G | AMPS | 1.00 | 1.00 | 2628 | 3298 |
| H | VOLTS | 1.37 | 1.37 | 3600 | 4518 |
| I | OHMS | 1.37 | 1.37 | 1.37 | 1.37 |
| J | AMPS | 1.00 | 0.59 | 2628 | 1957 |
| K | VOLTS | 1.37 | 0.81 | 3600 | 2682 |
| L | OHMS | 1.00 | 1.00 | 1.0 | 1.0 |
| M | AMPS | 0 | 0.41 | 0 | 1341 |
| N | VOLTS | 0 | 0.41 | 0 | 1341 |
| O | VOLTS | 1.37 | 0.41 | 3600 | 1341 |

In order to improve this situation, a single ground with an effective impedance of 1Ω can be hypothetically added at the load point. See Figure 2, Scenario 2. This creates a parallel path for the flow of current back from point A to the system source. In this extremely simplified case, the NTE voltage at point A would be reduced to 0.41 volts. While this is a simplified version of conditions on an electrical distribution system, the example does illustrate the principles involved in reduced NTE voltage through grounding.

Current in the distribution system neutral is not solely caused by customer load on single-phase taps. It can also come from unbalanced load on multigrounded wye three-phase lines. The neutral current is created when the single-phase loads connected to each phase are unequal and a resultant neutral current is created. Good distribution grounding will reduce the NTE voltage along the neutral path.

A special case of unbalanced single-phase load creating neutral current is the application of single-phase capacitors. Each 50 kVAC unit creates a capacitive current of seven amperes on a 7.2 kV system. If this is not locally compensated by an equal reactive current, it adds to the system neutral current and, thereby increases NTE voltage. Again, effective neutral grounding will reduce the resulting NTE voltage.

B. Electrical Faults on Customer Wiring

A second source of steady-state NTE voltage is improper wiring on customer premises. For example, if an energized conductor contacts an unbonded well casing, the resistance of the circuit between the well casing and the secondary neutral may be high enough to limit the current flow below a value that would result in tripping of the low-voltage breaker. As illustrated in Figure 3, if the well casing (in this case unbonded) has a resistance to remote earth of 6 ohms and the distribution system neutral has an effective resistance of 4 ohms, the fault current is 12 amperes, which is insufficient to operate the circuit breaker. The flow of 12 amperes through the neutral-to-earth resistance of 4 ohms at Point A will create a potential of 48 volts between the neutral and earth. The fault current through the resistance at Point B will create a voltage between the well casing and remote earth of 72 volts. The relative voltage at each point will be inversely related to the impedance of each earth connection. If the well casing is bonded to the premises grounding system as required by NEC-2002 Article 250.112(M), the breaker operates and these potentially hazardous voltages do not occur. However, this bond is sometimes missing.

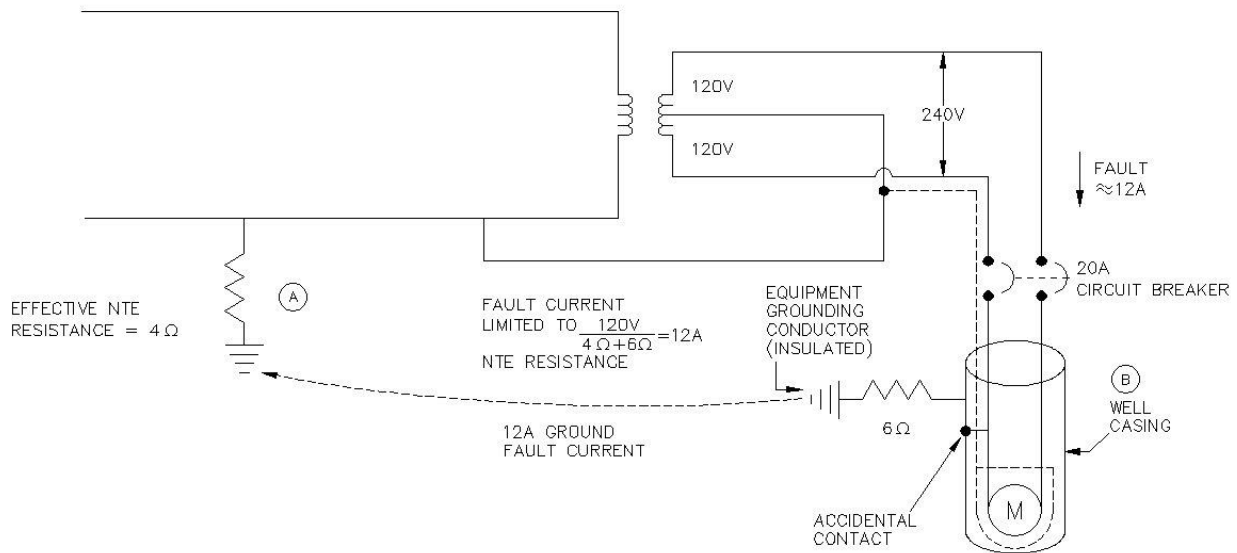

FIGURE 3 - CUSTOMER WIRING FAULT EXAMPLE

C. Faults on Utility Primary System

The most common type of short circuit on the multigrounded wye distribution system is the phase-to-ground fault. This can occur either on three-phase feeders or on single-phase tap lines. Regardless of location, the effect upon neutral-to-earth voltage is essentially the same. This

condition is principally differentiated from the steady state 60 Hz condition by the magnitude of the currents which are flowing in the distribution system neutral. The magnitude of the fault current which flows through phase conductors is partially determined by the impedance of the neutral/grounding system network. Lower neutral-to-earth resistance will reduce the effective impedance of the neutral/earth network and thereby generally result in a slightly higher current for a given fault situation. This can facilitate practical overcurrent coordination solutions.

The analysis illustrated in Figure 2, Scenario 3, shows a 7.2 kV single-phase line with an ungrounded neutral and a bolted phase-to-neutral fault ahead of the transformer primary winding. The voltage drop along the neutral is the same as the voltage drop along the phase conductor. This means that the 7200 volts of source potential is divided equally between phase wire and the neutral. This results in a 3600 volt neutral-to-earth potential at the fault location and at all points beyond. The consequent safety hazards of this hypothetical situation without a transformer ground electrode are obvious.

In Figure 2, Scenario 4, a more realistic scenario is presented, similar to Figure 2, Scenario 2. It can be seen that even with a 1 Ω neutral-to-earth impedance at the point of the fault the NTE neutral-to-earth potential is approximately 1341 volts. Obviously, appropriate bonding and additional grounding of the distribution system neutral is needed to ensure safety.

Another aspect of phase-to-ground faults on a multigrounded wye primary system is the electrical shift of the neutral due to flow of fault current in the neutral path. This manifests itself in elevated voltage between the neutral and remote earth with consequent current flows from the neutral to earth. It also results in a temporary elevated voltage between the neutral and the unfaulted phases. For an effectively grounded system this will result in a transient phase-to-ground voltage of less than 2.0 pu. This is to be expected when $X_0/X_{\square} < 3.0$ and $R_0/X_{\square} < 1.0$. With improved grounding and neutral arrangement it is possible to bring $X_0/X_{\square} \leq 1.0$ and $R_0/X_{\square} \leq 0.1$ with an anticipated maximum transient phase-to-neutral voltage of 1.5 pu. A consequence of having the distribution system neutral effectively grounded is not only lower transient 60 Hz voltages delivered to customers on the unfaulted phases, but the rating of lightning arresters can also be lower. This allows arrester discharge voltages to be lower and improves overvoltage protective margins for distribution transformers and other equipment.

D. High Resistance Splice

No distribution system exists without splices or other current-carrying connections in the neutral conductor. Multiple splices appear where the neutral is installed under dif-

ferent projects, where reels of wire end, and where conductors are broken during weather events or by foreign objects. While all splices are designed to give a lower resistance than an equivalent length of the conductor, installation practices and corrosion can sometimes cause the resistance of a splice to be higher than designed values. In Figure 2, Scenario 2, a resistance of 0.20 ohms is added in the neutral circuit to illustrate the effect of a high resistance joint. With a hypothetical single-point ground of 1.0 ohms at the load, this raises the NTE potential to 0.44 volts in contrast with the 0.41 volts for an intact neutral conductor. This is a 7.3% increase for only a 0.20 ohm resistance in a single splice. With the presence of multiple splices in a typical distribution circuit neutral conductor, it can be seen that without effective neutral grounding this could build to a significant problem, even if only a relatively small percentage of the splices are defective.

To illustrate the effect of multiple system grounds, we contemplate the case of improved system grounding beyond the "high resistance" neutral connection. Ten adequately spaced ground rods, each with a resistance of 25 ohms, is the approximate equivalent of adding a 2.5 ohm ground. This will reduce the NTE voltage by 11% in this simplified example.

V. SURGE DISSIPATION

A very important function of the grounding in a multigrounded wye distribution system is the dissipation of surges which are caused by lightning strokes near the distribution system. If the lightning charge is not effectively dissipated, the result can be flashover of insulation systems, utility equipment damage, and surges into the customer premises. Of course, the most important component in equipment protection is a properly installed lightning arrester. Depending upon the particular surge arrester arrangement, the importance of a neutral-to-earth connection can range from extremely important to immaterial for the overvoltage protection function. The following examples are offered to illustrate the influence of the grounding electrode impedance for various circumstances.

A. Equipment Protection

On a multigrounded wye system, if an item of equipment has an arrester mounted on the tank, the surge current discharged by the arrester is passed through the tank and directly to the system neutral which serves as a grounding conductor for the equipment tank. The arrester has accomplished its function of reducing the voltage across the equipment insulation system. By virtue of its close connection between the primary conductor and the equipment tank, the optimum equipment protection has been achieved regardless of whether there is an effective earth ground at this location. However, in this case the lightning charge has been shunted from the primary conductor to the neutral

conductor. If there is not an effective ground electrode at this point, the lightning surge will then propagate along the system neutral until it can be transferred to earth through grounding. During the surge, the rise in the neutral voltage relative to remote earth is a function of the distance to effective grounding electrodes and the surge impedance of the path(s). As explained below, even the presence of a ground electrode at the arrester location will result in a surge voltage being present on the neutral. The magnitude of this voltage is a function of surge magnitude, wave shape, downlead length and grounding electrode surge impedance. The importance of the surge voltage on the neutral lies in the effect which this can have on customer premises which are interconnected with the system neutral. One of the paths along which the surge current is dissipated in the secondary neutral. See Figure _____. This means that part of the current travels through the customer's service entrance grounding electrode. Since the service entrance ground generally has a higher impedance than the utility equipment ground, a lesser portion of the total discharge current travels along this neutral path and in itself is not detrimental to customer premises which have good bonding in place. However, with secondary service cables in a triplex configuration, a surge current traveling through the triplex cable neutral will induce a voltage between the neutral and the energized conductors surrounding the neutral. [F2,F7] The surge voltage induced in the energized conductors is proportional to the surge current in the secondary neutral which is a function of the relative impedances to earth of the distribution system neutral and the customer premises grounding system. If the system neutral ground impedance is high in relation to the customer ground, more of the current will travel along the service neutral and the induced voltage will be higher. This induced voltage will be present at both ends of the service. Thus it is apparent that a high impedance earth ground at a utility equipment location can have an adverse effect on both the customer and the utility transformer secondary windings, even when protection of the transformer primary winding has been effectively accomplished. Therefore, one important component of total system surge protection is an effective equipment ground electrode at transformers.

B. Line Protection

Another function of the distribution arrester is the prevention of flashovers between the primary conductors and the structure (or other phase conductors) during direct or nearby strokes. Here the lightning surge current must be transferred from the primary conductors to earth as effectively as possible in order to minimize the voltage existing across the structure insulation system. This minimizes the

probability of a phase-to-ground flashover which will cause facility damage and/or line interruption. The voltage from the primary conductor to earth during an arrester discharge depends to a significant extent on the resistance to earth of the grounding electrode at the arrester location. See Figure 4. The local grounding electrode resistance will partially determine the surge voltage between the protected conductor and other parts of the structure if only one phase is protected. However, for the more common case where all energized conductors have surge protection, only the arrester characteristics and the length of the arrester leads determine the degree of protection against flashover between conductors. Since the objective is to prevent flashover on the structure or between the energized conductors, the equalization of voltages at the pole top is sometimes adequate to accomplish the desired result. However, the presence of a low impedance grounding electrode at the arrester location will enhance charge dissipation from both the neutral and the energized conductors. This will reduce the magnitude of the wave propagated along both the energized conductors and along the system neutral. Therefore, it is apparent that while structure flashover performance might be improved without an effective grounding electrode at the arrester location, total performance of a practical distribution system still requires a low impedance arrester ground.

C. Underground Protection

The local grounding of underground cable dips is a special case of surge protection. Underground equipment susceptibility to lightning surges and the wavefront doubling phenomenon on underground cables makes reduction of wavefront magnitude very important. The surge voltage imposed on the primary cable system and attached equipment is most effectively reduced by close connection of the lightning arrester to the cable terminations. This is accomplished by minimizing the effective lead length. The effectiveness of cable and equipment protection is not strongly dependant on riser pole ground electrode resistance. However, the arrester discharge at a properly installed pole-top termination also imposes a surge current (and voltage) on the pole ground and the cable concentric neutral or shield.

In bare concentric neutral (BCN) cables the cable neutral surge current is then dispersed to earth in the immediate vicinity of the pole. For jacketed concentric neutral (JCN) cables there will exist a voltage across the jacket which will be proportional to the share of arrester discharge current passed along the cable neutral. Therefore, to minimize the probability of jacket punctures, and attendant corrosion potential for the neutral, the resistance

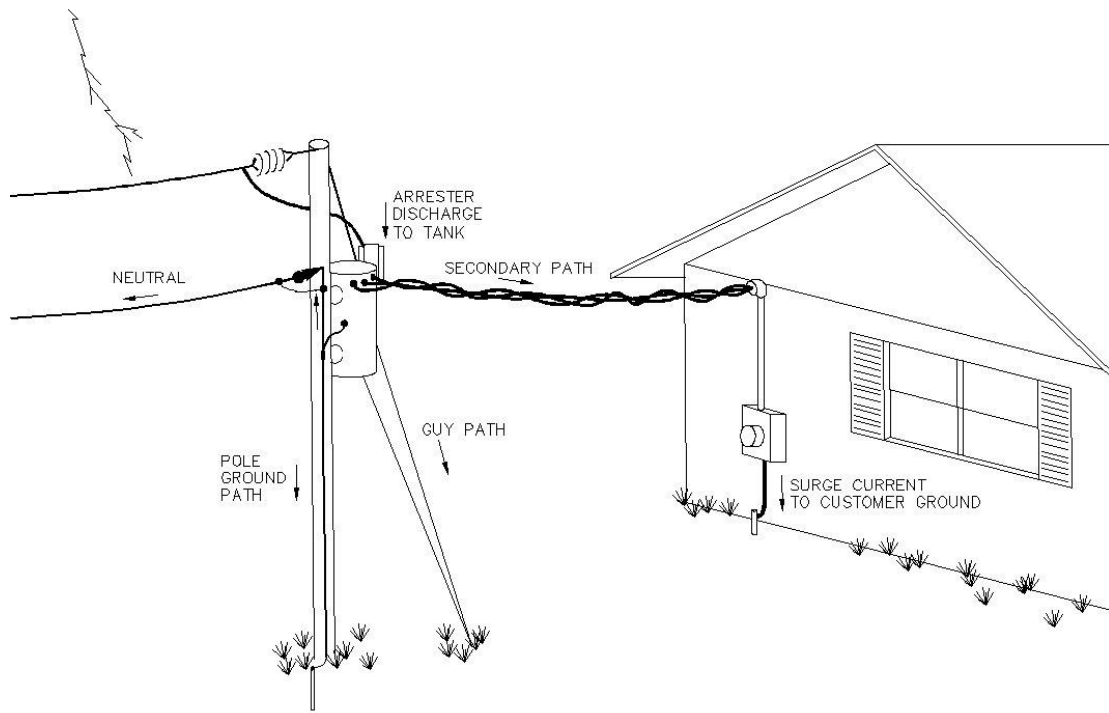

FIGURE 4 - ARRESTER DISCHARGE CURRENT DISTRIBUTION - OVERHEAD

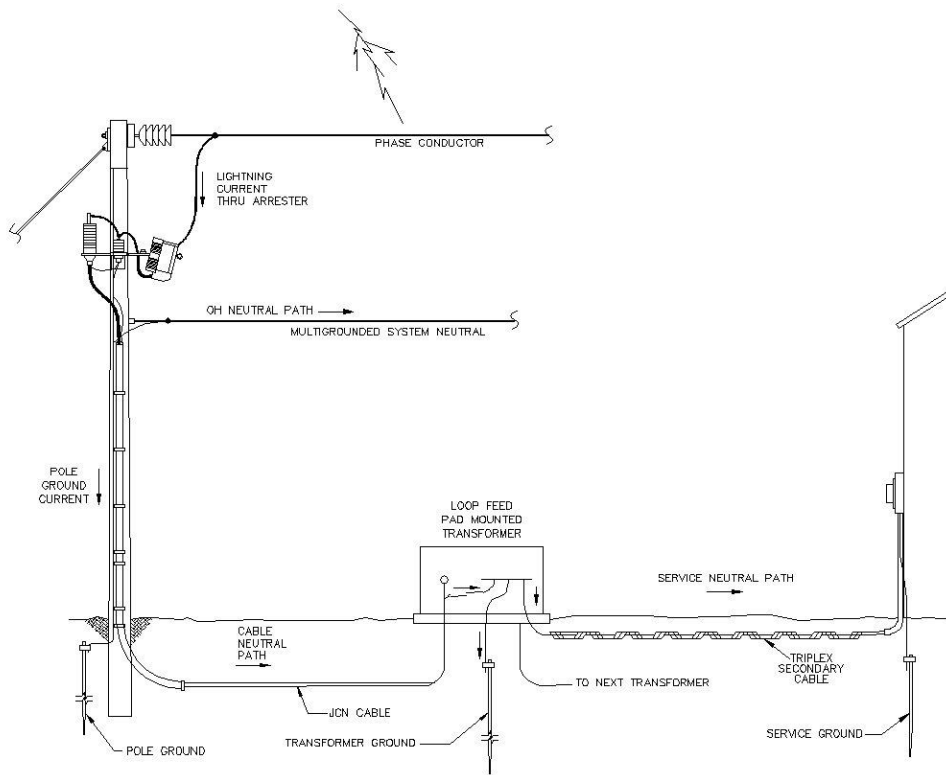

FIGURE 5 - ARRESTER DISCHARGE CURRENT DISTRIBUTION - UNDERGROUND

of the riser pole grounding electrode should be kept as low as practical. A target resistance of 10 Ω is considered desirable.

The amount of current distributed into the riser pole ground electrode, the system neutral and the cable neutral is dependant on the relative impedances of each. When the current surge passed along the JCN cable neutral reaches the first transformer, there is a partial dispersion of this neutral surge current among the transformer grounding electrode, other JCN primary neutrals and the secondary service neutrals originating at the transformer. Therefore, part of the riser pole arrester discharge current can be eventually transferred to the customer's service entrance ground electrode with the secondary surge induction problems described elsewhere in this paper. This is additional justification for keeping grounding electrode resistance low at both the riser pole and the padmount transformer.

D. Grounding System Surge Impedance

Consideration of grounding system surge dissipation effectiveness must recognize two very important differences between surge dissipation and 60 Hz system grounding. First is the extremely steep wavefront associated with lightning strokes and lightning arrester discharge currents. Lightning currents have a wavefront dI/dt on the order of 4 to 15 kA per microsecond (kA/ μ s), whereas a 60 Hz waveform on 7.2 kV system has a rise time on the order of 0.0012 kV/ μ s. This means that the inductance of any conductor, regardless of size, becomes very large compared to the resistance of that conductor. The surge voltage in down-lead conductors may be in the range of 1.6-10 kV/foot. Therefore, grounding electrodes separated from the stroke location can contribute very little to lowering the system impedance seen by the surge current. This means that the dissipation of surge current depends upon the effectiveness of grounding electrodes in the immediate vicinity of the location where the surge current is imposed upon the system by a lightning arrester or a system flashover.

The second important aspect of grounding system surge impedance is the behavior of grounding electrodes under high current discharges. Since the impedance of the electrode to remote earth occurs as the resistance of concentric shells of earth surrounding the electrode, the passage of the high momentary current associated with an arrester discharge will produce a high impulse voltage gradient in the immediate vicinity of the ground electrode. This high voltage gradient, occurring within the soil, will result in arcing through the soil interstices. The presence of these microarcs bridge the higher resistance components of the soil structure and thus momentarily lower the electrode resistance to remote earth during the discharge event. Of course, the magnitude of this effect is strongly dependent on soil particle resistance, soil moisture resistivity and the soil void ratio. Sandy open-grain soils will generally exhibit a greater per-

cent reduction in electrode impedance than tight-grained clays. [E18, E19]. This is illustrated in Figure 6. It can be seen that for impulse currents of 5000 amperes the impedance of electrodes in sandy soils may be reduced to the range of 40-50% of their 60 Hz values. Under similar conditions electrodes in clays are reduced to 60-80% of their 60 Hz values. However, those grounds which have the lowest 60 Hz impedance always achieve the lowest surge impedance.

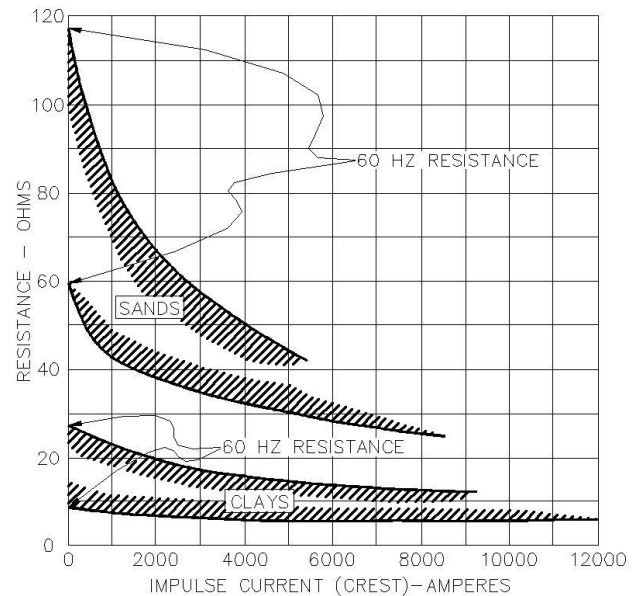

FIGURE 6—VARIATION OF ELECTRODE IMPULSE RESISTANCE FROM 60 Hz RESISTANCE FOR TWO SOIL TYPES

VI. BONDING BETWEEN PRIMARY SYSTEM NEUTRAL, TELEPHONE, CATV, AND WATER SYSTEMS

Typically, electric distribution line primary neutrals are bonded to telephone and CATV strands on joint use lines. This creates an equipotential condition between the individual messenger strands and the neutral. This reduces the likelihood of hazardous voltages between non-current carrying parts on poles and, by extension, on underground systems.

Communication utilities often do not realize that their support strands frequently function as part of the neutral return path for the electric utility system. Because of this, communication workers should exercise caution when connecting and disconnecting grounding and bonding connections on their support strand. If the impedance of the electric system neutral has increased for some reason, such as a high-resistance splice, the communication strand may carry a significant portion of neutral current. The current sharing is a function of the relative impedances of the electric system neutral and the respective communication mes-

sengers and/or shields. Coaxial cables such as found in cable television systems provide a particularly low impedance path. The current and associated potentials may become a personnel hazard if communication personnel do not follow appropriate work rules.

A very positive aspect of bonding between the distribution system neutral and the communication system is the effect which this has on the effectiveness of communication cable sheaths. The sheath efficiency in preventing magnetic induction in communication conductors is strongly dependent on the presence of a low impedance connection to earth at each end of an exposed cable section. Bonding of the sheath to an effectively grounded distribution system neutral provides these ground connections for the sheath.

Although metallic water lines have been used in the past as grounding electrodes, electric utilities typically do not bond to these systems except at the served structure. See Section VII.

VII. CODE REQUIREMENTS

A. NESC [A1] - Utility Grounding and Bonding

The requirement to ground utility systems is contained in NESC Rule 215 for overhead systems and Rule 314 for underground systems. For purposes of discussion and to avoid duplication, the overhead rules will be referenced, although similar underground rules also exist.

NESC Rule 97G requires grounded items on joint-use poles to be bonded by either using a single grounding conductor or bonding the supply grounding conductor to the communication grounding conductor, except where separation is required by Rule 97A. Where separation is maintained according to Rule 97A, insulation may be required on the grounding conductor(s), since there may be a hazardous potential voltage difference between the two conductors. NESC Rule 215C3 requires bonding between messengers at typically four times in each mile, which is consistent with the requirement to ground supply neutrals not less than four times in each mile.

Electric and communication systems are required by both the NESC and NEC to utilize the same grounding system at a structure receiving electric and communication service. Although NESC Rule 099 allows and specifies grounding electrodes for communication systems, when the two utilities provide service to a common building structure, they are required to create a common grounding electrode system for the served structure. If the two (or more) utilities decide, for whatever reason, to install their own grounding electrodes (as with different service entrance locations), NESC Rule 099C requires the separate electrode systems to be bonded with a conductor not smaller than AWG No. 6

copper. National Electrical Code Article 800-40(d) has corresponding requirements for systems subject to that Code.

If the electric system service and communication system service do not utilize the same grounding system, as required by the NESC or NEC, the different systems may create a potential for equipment damage due to voltage surges. For example, the charging base for the cordless telephone set utilizes the electric system for powering the charging system. As a result, if the grounding systems are not bonded, there could be two separate grounding systems within the body of the charging base. A voltage surge from a lightning impulse (or any other source) imposed on one grounding system may jump the gap between the two systems in an attempt to equalize the potential, damaging the equipment. The same can be said for a cable-ready television, VCR, computer modem, or other piece of communication equipment. Many satellite receiving units have a telephone connection for communicating with the satellite company. This presents a similar problem if the systems are not properly bonded.

B. NEC [A2] - User Grounding and Bonding

Similar requirements for grounding and bonding are contained in the National Electrical Code (NEC). However, the system neutral of the utilization wiring system of a building or structure is not utilized for grounding as is the neutral of the electric distribution multigrounded neutral system. In utilization wiring systems, the voltage drop on the neutral, if also used for equipment grounding, could result in voltage differences between the exposed metallic frames and cases of electrical equipment and appliances. This could produce a hazard to personnel or even a fire hazard.

NEC Article 250.24(A)(5) prohibits the bonding of the neutral and equipment grounding conductor beyond the service disconnect. It should be noted that NEC Article 250.104 requires electrical bonding to metal water pipes installed in or attached to a building or structure. This limits the opportunity for a voltage potential difference to exist between the water system and other non-current carrying parts within the building. However, it should also be noted that NEC Article 250.52(A)(1) prohibits using interior metal water piping located more than 5 feet from the entrance to the building from being used to interconnect grounding electrodes within a building. Note that any replacement of metallic water pipes utilizing nonmetallic water pipes would interrupt the electrical continuity being provided by the metallic water pipes.

VIII. CONCLUSIONS

The optimum performance of the multigrounded neutral distribution system is dependent on a good connection between the neutral and earth. Advantages of adequate neutral grounding include the following:

- Improved public and utility personnel safety by reducing steady state neutral-to-earth voltages.
- Reduced transient neutral-to-earth voltages occurring during phase-to-ground faults.
- Contributes to reduced surge voltage on customer systems during lightning arrester operations.
- Improved cable and equipment protection on underground systems.
- Reduced current flow into bonded systems or development of elevated neutral-to-earth voltages in case of a broken neutral.

These points show the need for continued attention to good system grounding practices, particularly in an era of increasing customer sensitivity to the effects of transient voltages.

IX. BIBLIOGRAPHY

The following list of references is provided to assist in locating more extensive treatment of various specialized topics related to grounding. It is apparent that this subject has been of interest to the distribution engineering community from the earliest days of the industry. This bibliography is not a complete listing of all articles written on the subject, but each reference will provide additional avenues for investigation by those interested in pursuing each topic further.

A. Codes

1. National Electrical Safety Code, 2002 Edition, (ANSI C2), Institute of Electrical and Electronics Engineers, 2001.
2. National Electrical Code, (NFPA 70) National Fire Protection Association.

B. General References and Texts

1. Electric Utility Engineering Reference Book - Distribution Systems, Westinghouse Electric Corporation. East Pittsburgh, PA 1959.
2. Electrical Transmission and Distribution Reference Book, 4th Edition, Westinghouse Electric Corporation, East Pittsburgh, PA, 1964.
3. Elements of Power System Analysis, by W.D. Stevenson, Jr., McGraw-Hill Book Company, New York, NY, 1975.

4. Distribution System Protection Manual, Cooper Power Systems, Milwaukee, WI, 1990.
5. Practical Utility Safety, by Allen L. Clapp, PE, PLS editor - Clapp Research Associates, Raleigh, NC, 1999.
6. Downed Power Lines: Why They Can't Always Be Detected, IEEE Power Engineering Society, PES-DPL-3, February 22, 1989.
7. Underground Distribution System Design and Installation Guide, RER Project 90-8, National Rural Electric Cooperative Association, Arlington, VA, 1993.
8. IEEE Guide for the Application of Neutral Grounding in Electric Utility Systems, Part I - , C62.92.1-2000.
9. IEEE Guide for the Application of Neutral Grounding in Electrical Utility Systems, Part IV-Distribution, C62.92.4-1991.
10. Ground Currents and the Myth of Stray Voltage, by O.C. SeEVERS, Fairmont Press, Lilburn, GA, 1989.
11. Soares' Grounding Electrical Distribution Systems for Safety, Third Edition; Wilford I. Summers, Editor; IAEI; 1986.

C. IEEE Standards and RUS Publications

1. Chapter VII. Lightning Protection and Chapters IX. Grounding.... Reference (1) REA Bulletin 83-1, Adequate Grounding on Distribution Lines.
2. IEEE Standard 81-1983, IEEE Guide for Measuring Earth Resistivity, Ground Impedance and Earth Surface Potentials of a Ground System.
3. IEEE Standard 80-2000, IEEE Guide for Safety in AC Substation Grounding. Institute of Electrical and Electronics Engineers. New York, NY, 2000.
4. IEEE Standard 80-1986, IEEE Guide for Safety in AC Substation Grounding. Institute of Electrical and Electronics Engineers. New York, NY, 1986.

D. Calculation Methods

1. An Analog Model of Neutral-to-Earth Voltages in a Single-Phase Distribution System. Hollis Shull; LaVerne E. Stetson, PE; Gerald R. Bodman, PE; IEEE Rural Electric Power Conference, CH1858-0-C1. 1983 Rural Electric Power Conference. Des Moines, Iowa. April 24-26, 1983.
2. Computer Analysis of Neutral-to-Earth Potentials on Rural Systems.... Edward S. Thomas, PE; Philip I. Monroe, EIT;

- IEEE No. 84 CH 1969-5. 1984 Rural Electric Power Conference Nashville, Tennessee. May 6-8, 1984.
3. Calculation of Ground Fault Current using an Equivalent Circuit and a Simplified Ladder Network.... L. Levey, IEEE Transactions on Power Apparatus and Systems, Vol. PAS-101, No. 8, August 1982.
 4. Network Analysis of Ground Currents in a Residential Distribution System.... D.L. Mader, L.E. Zaffanella, IEEE Transactions on Power Delivery, Vol. 8, No. 1, January 1993.
 5. A Numerical Formulation for Grounding Analysis in Stratified Soils. Ignasi Colominas, Fermin Navarrina, and Manuel Casteleiro. IEEE Transactions on Power Delivery, Vol. 17, No. 2, April 2002.
 6. Analysis of Complex Grounding Systems Consisting of Foundation Grounding Systems with External Grids. M.B. Kostic, IEEE Transactions on Power Delivery, Vol. 13, No. 3, July 1998.
 7. Grounding System Analysis in Transients Programs Applying Electromagnetic Field Approach. Markus Heimbach. IEEE Transactions on Power Delivery, Vol. 12, No. 1, January 1997.
 8. Simplified Two Layer Model Substation Ground Grid Design Methodology. J. Lazzara, N. Barbeito, Petersburg, Florida.
 9. Elegant Ground Fault Solutions for Impossible Problems. David L. Swindler, IEEE Transactions on Industry Applications, Vol. 37, No. 1, January/February 2001.
 10. Distribution Line Performance with Imperfect Grounding. John M. Undrill, and Roger E. Clayton, IEEE Transactions on Industry Applications, Vol. 24, No. 5, September/October 1988.
 11. Computer Analysis of Impedance Effects in Large Grounding Systems. Ian B. Simpson, David J. Bensted, Farid Dawalibi, and Einar D. Blix, IEEE Transactions on Industry Applications, Vol. 1A-23, No. 3, May/June 1987.
 12. A Complete Field Analysis of Substation Ground Grid by Applying Continuous Low Voltage Fault. Shashi G. Patel, IEEE Transactions on Power Apparatus and Systems, Vol. PAS-104, No. 8, August 1985.
 13. Review of Analytical Methods for Calculating the Performance of Large Grounding Electrodes. Part I: Theoretical Considerations. R.P. Nagar. R. Velazquez. Mansour Loeloeian, Dinkar Mukhedkar. Y. Gervais. IEEE Transactions on Power Apparatus and Systems, Vol. PAS-104, No. 11, November 1985.
 14. Review of Analytical Methods for Calculating the Performance of Large Grounding Electrodes. Part II: Numerical Results. Mansour Loeloeian, R. Velazquez, Dinkar Mukhedkar, IEEE Transactions on P.A. System PAS-104, No. 11, November 1985.
 15. Sensitivity Analysis of the Total Accident Probability of a Grounding System. Wen Wang, Dinkar Mukhedkar, Yvon Gervais, IEEE Transactions on Power Apparatus and Systems, Vol. PAS-104, No. 7, July 1985.
 16. Computer Assisted Design of Substation Grounding. R. Giordano, D.A. Mark, C.J. Rostkowski, B. Schall, K.O. Sommer. IEEE Transactions on Power Apparatus and Systems, Vol. PAS-104, No. 7, July 1985.
 17. Current for Design of Grounding Systems. B. Thepar, Chandigarh Sunil K. Madan, IEEE Transactions on Power Apparatus and Systems, Vol. PAS-103, No. 9, September 1984.
 18. Transient Analysis of Grounding Systems. A.P. Meliopoulos, M.G. Moharom, IEEE Transactions on Power Apparatus and Systems, Vol. PAS-102, No. 2, February 1983.
 19. Transmission Line Tower Grounding Performance in Non-Uniform Soil. F. Dawalibi, W.G. Finney, IEEE Transactions on Power Apparatus and Systems, Vol. PAS-99, No. 2, March/April 1980.
- ### E. Grounding
1. Two Efficient Configurations of Grounding Electrodes for Electric Distribution Systems.... Baldev Thapar, Victor Gerez, Harsh Kejriwal, Thomas J. Kendrew, IEEE 93SM 405-1 PWRD, T-PWRD April 1994.
 2. Grounding Electrode to Earth Resistance and Earth Voltage Gradient Measurements.... T.C. Surbrook, M.D. Reese, Charles Jensen, Paper No. 82-3507, December 1982. 1982 Winter Meeting American Society of Agricultural Engineering. Palmer House Hotel, Chicago, IL. December 14-17, 1982.
 3. Analysis of Grounding Systems.... A.P. Meliopoulos, R.C. Webb, E.B. Joy, IEEE Transactions on Power Apparatus and Systems, Vol. PAS-100, No. 3 March 1981.
 4. Effects of Grounding on Distribution System Harmonic Resonance Conditions.... A.P. Sakis Meliopoulos, G.J. Cokkinides, K.R. Chakravarthi; IEEE Transactions on Power Delivery, Vol. 4, No. 1, January 1989.
 5. Temporary Protective Grounding of Distribution Circuits.... Raymond E. Mueller, Earl F. Richard, IEEE Rural Electric Power Conference CH1532-1-1A-C4. 1980 Rural Electric

- Power Conference. Rapid City, South Dakota. April 27-29, 1980.
6. Bentonite Rods Assure Ground Rod Installation in Problem Soils.... Warren R. Jones, IEEE Transactions on Power Apparatus Systems, Vol. PAS 99, No. 4 July / August 1980.
 7. A Comparison of International Residential Grounding Practices and Associated Magnetic Fields. Gregory B. Rauch. Gary Johnson, Paul Johnson, Andreas Stamm, Seietsu Tomita, John Swanson, IEEE Transactions on Power Delivery, Vol. 7, No. 2, April 1992.
 8. Evaluation of Ground Resistance of a Grounding Grid of Any Shape. Baldev Thapar, Senior, Victor Geiez, Arun Balakrishnan, Donald A. Blank, IEEE Transactions on Power Delivery, Vol. 6, No. 2, April 1991.
 9. Mine Power-System Grounding Research. Wils L. Cooley and Herman W. Hill, Jr., IEEE Transactions on Industry Applications, Vol. 24, No. 5, September/October 1988.
 10. Grounding Where Corrosion Protection is Required. Donald H. McIntosh, IEEE Transactions on Industry Applications, Vol. IA-18, No. 6, November/December 1982.
 11. Safe Substation Grounding - Part I: J.G. Sverak, W.K. Dick, T.H. Dodds, R.H. Heppe. IEEE Transactions on Power Apparatus and Systems, Vol. PAS-100, No. 9, September 1981.
 12. Safe Substation Grounding - Part II: J.G. Sverak, R.H. Benson, W.K. Dick, T.H. Dodds, D.L. Garret, J.E. Idzkowski, R.P. Keil, S.G. Peter, M.E. Ragen, G.E. Smith, R. Verma and L.G. Zukerman. IEEE Transactions on Power Apparatus and Systems, Vol. PAS-101, No. 10, October 1982.
 13. Impulse and Alternating Current Tests on Grounding Electrodes in Soil Environment. William K. Dick, Harvey R. Holliday, IEEE Transactions on Power Apparatus & Systems, Vol. PAS-97, No. 1, January/February 1978.
 14. "The Use of Concrete-Enclosed Reinforcing Rods as Grounding Electrodes," Fagan, E.J. and Lee, R.H., IEEE Transactions on Industry Applications, Vol. IGA-6, No. 4, July / August 1970.
 15. "General Considerations in Grounding the Neutral of Power Systems," by H.H. Dewey, A.I.E.E., Pittsburgh, PA April 24-26, 1923.
 16. "Grounding of High Potential Systems", by J.D. Niles, Electrical World and Engineer, April 12, 1902.
 17. 15 August 1973 Draft of NESC Part 2 1977 Edition, Institute of Electrical and Electronics Engineers; New York, New York, 1973.
 18. Impulse and 60-cycle Characteristics of Driven Grounds, P.L. Bellaschi, AIEE Transactions, Vol. 60, 1941.
 19. Impulse and 60-cycle characteristics of Driven Grounds-II, P.L. Bellaschi, R.E. Armington, A.E. Snowden. AIEE Transactions, Vol. 61, 1941.
 20. Ground Current Magnetic Field Study, Research Report EP 90-50, N.Y. Institute of Technology, Empire State Electric Energy Research Corporation, January 1993.
- ### F. Equipment Protection
1. Full Scale Lightning Surge Tests of Distribution Transformers and Secondary Systems.... Gary L. Goedde, Roger C. Dugan, Lawrence D. Rowe, IEEE Transactions on Power Delivery, July 1992, Volume 7, No. 3.
 2. Susceptibility of Distribution Transformers to Low Voltage Side Lightning Surge Failure.... C.J. McMillen, C.W. Schoendube; D.W. Caverly, IEEE Transactions on Power Apparatus and Systems, Vol. PAS-101, No. 9, September 1982.
 3. A Guide to the Application of Surge Arresters for Transformers Protection.... Dennis A. Zolar, IEEE Transactions on Industry Applications, Vol. 1A-15, No. 6, November / December 1979.
 4. Distribution Surge Arrester Behavior Due to Lightning Induced Voltages.... Shigeru Yokoyama, IEEE Transactions on Power Delivery, Vol. PWRD, No. 1, January 1986.
 5. Distribution Arrester Failures Caused by Lightning Current Flowing from Customer's Structure into Distribution Lines.... K. Nakada, T. Wakai, H. Taniguchi, T. Kawabata, S. Yokoyama, T. Yokota, A. Asakawa, IEEE Transactions on Power Delivery, Vol. 14, No. 4, October 1999.
 6. Lightning Protection of Distribution Lines.... T.E. McDermott, T.A. Short, J.C. Anderson, IEEE Transactions on Power Delivery, Vol. 9, No. 1, January 1994.
 7. Reduction in Distribution Transformer Failure Rates and Nuisance Outages Using Improved Lightning Protection Concepts.... Charles W. Plummer, Gary L. Geodder, PE, Elmer L. Pettit, Jr. PE, Jeffrey S. Godbee, Michael G. Hennessey, PE, 94 TD038, T-PWRD April 1995. IEEE Transactions on Power Delivery, Vol. 10, No. 2, April 1995.
 8. Distribution Lightning Protection Past, Present, Future.... Dee C. Parrish, Carroll Electric Membership Corporation. Reference: IEEE Rural Electric Conference Paper No. CH 1654-3 1981. 1981 Rural Electric Power Conference. Atlanta, Georgia. April 26-28, 1981.

9. Protection of Underground Systems Using Metal-Oxide Surge Arresters.... W.D. Niebubr, IEEE Rural Electric Power Conference Paper No. CH 1654-3 1981. 1981 Rural Electric Power Conference. Atlanta, Georgia. April 26-28, 1981

G. Lightning

1. Estimating Lightning Performance of Transmission Lines II - Updates to Analytical Models.... IEEE Working Group Report. 92 SM453-1 PWRD, T-PWRD July 1993 - IEEE Transactions on Power Delivery. Vol. 8, No. 3, July 1993.
2. Lightning-induced Voltage on an Overhead Wire Dependent on Ground Conductivity.... Masaru Ishii, Koji Michishita, Yasuji Hongo, Syujiro Oguma. 93 WM 092-7 PWRD, T-PWRD January 1994.
3. Laboratory Studies of The Effects of Multipulse Lightning Currents on Distribution Surge Arresters.... M. Darveniza and D.R. Mercer, 92SM 355-8 PWRD, T-PWRD July 1993.
4. Lightning-Induced Voltages on Overhead Power Lines. Part I.... C.A. Nucci, Working Group 33.01 (Lightning). (CIGRE) Electra No. 161, August 1995.
5. Lightning-Induced Voltages on Overhead Power Lines. Part II.... C.A. Nucci, Task Force 33.01.01 (lightning induced voltages) of Study Committee 33. Electra No. 162, October, 1995.
6. Frequency of Distribution Arrestor Discharge Currents Due to Direct Strokes.... Gordon W. Brown, Steven Thunander, IEEE Transactions on Power Apparatus and Systems, Vol. PAS-95, No. 5, September / October 1976.

H. Power Quality and Communication Systems

1. Transformer Grounding According to the National Electric Code.... Mike Holt, Power Quality Assurance - July / August 1998.
2. Transformer Grounding and Transferred Earth Potentials.... Tom Shaughnessy, Power Quality Assurance - September / October 1998.
3. The Foundations of Good Grounding.... Tom Shaughnessy, Power Quality Assurance - January / February 1998.
4. Types of Grounding Systems.... Tom Shaughnessy, Power Quality Assurance - July / August 1998.
5. Lightning Can Teach Important Lessons About Power Protection.... Mark Mull and George Bowden, Power Quality Assurance - July / August 1998.

6. Understanding the Proliferation of Power Grounding and Protection Standards.... William Bush, Power Quality Assurance - January / February 1994.

7. Grounding-Part 1 - Basic Principles.... Mark Waller. Power Quality. Premier 111 1990.

8. Industrial System Grounding for Power, Static, Lightning and Instrumentation, Practical Applications. Philip W. Rowland, IEEE Transactions on Industry Applications, Vol. 31, No. 6, November/December 1995.

9. Discussions of "Industrial System Grounding for Power Static, Lightning and Instrumentation. Richard Singer. IEEE Transactions on Industry Applications, Vol. 32, No. 5, September/October 1996.

I. Stray Voltage

1. Source of Stray Voltage and Effect on Cow Health and Performance.... R.D. Appleman and R.J. Gustafson, Journal of Dairy Science, August 23, 1984.

2. Techniques for Coping with Stray Voltages.... Robert J. Gustafson, Harold A. Cloud, Vernon D. Albertson, Agricultural Engineering - December 1984.

3. Response of Dairy Cattle to Transient Voltages and Magnetic Fields.... Douglas J. Reinemann, LaVerne E. Stetson, Nellie K. Laughlin, 1994 IEEE Rural Electric Power Conference Colorado Springs, Colorado - Paper 94 C5.

4. Neutral-to-Earth Voltage and Ground Current Effects in Livestock Facilities.... R.J. Gustafson, V.D. Albertson, IEEE Transactions on Power Apparatus and Systems, Vol. PAS-101, No. 7, July 1982.

5. Stray Voltage: Sources and Solutions.... Truman Surbrook, PE; Norman Reese, PE; Angela Kebole, IEEE Rural Electric Power Conference Paper No. 84CH 1969-5 B5. 1984 Rural Electric Power Conference. Nashville, Tennessee, May 6-8, 1984.

6. Stray Voltage Update 97.... Douglas J. Reinemann, PhD, LaVerne E. Stetson, Daniel M. Dasbo and Mark A. Cook, 1997 IEEE Rural Electric Power Conference Minneapolis, Minnesota, April 20-27, 1997.

7. Understanding and Dealing with Stray Voltage in Livestock Facilities. Robert J. Gustafson, Reference: IEEE Rural Electric Power Conference, Paper No. CH 126-1 1985. (85 C2.) 1985 Rural Electric Power Conference, Springfield, Illinois. April 28-30, 1985.

8. Stray Voltage on the Dairy Farm.... Richard S. Seeling, PE, IEEE Rural Electric Conference. Paper No. 80 C4 CH 1532-

1 1980. 1980 Rural Electric Power Conference, Rapid City, South Dakota. April 27-29, 1980.

AUTHORS:

Edward S. Thomas, PE (SM) holds a bachelor of science degree from North Carolina State University. He has worked in the electric distribution field since 1964 with Duke Power, Piedmont EMC and engineering consulting firms. Thomas is president of Utility Electrical Consultants, PC in Raleigh, NC, a firm providing consulting engineering services to utilities and other owners of medium and high voltage systems. Thomas is a registered engineer in North Carolina and ten other states. He was the editor of a manual on underground system design, the author or principal co-author of five previous papers on distribution systems and author of a recent analysis of distribution transformer protection methods.

John B. Dagenhart, P.E. (SM) is an Associate of Clapp Research Associates, P.C., and is lead engineer for many of CRA's electrical projects. He has investigated over 100 accidents. John is chair of NESC Subcommittee 2 on Grounding Methods and serves on the IEEE/NESC Lecture Team. He regularly presents DANESC™ Seminars for CRA clients, and is an authorized OSHA construction regulations instructor.

Mr. Dagenhart is a contributor to McGraw-Hill's Standard Handbook for Electrical Engineers, an associate editor of the DANESC UPDATE™ Newsletter; provided research for the NESC Handbook; co-authored and edited Power Systems Disturbances Manual for Duke Power Company; contributed to the upcoming IEEE Emerald Book Powering and Grounding Sensitive Electronic Equipment; and authored or co-authored articles on electrical power quality issues and both the National Electrical Safety Code (NESC) and the National Electrical Code (NEC).

Allen L. Clapp, P.E., P.L.S. (SM) is President of Clapp Research Associates, P.C., Consulting Engineers. The firm serves over 250 utilities and industries. Allen has been involved in the design and evaluation of electric supply and communication facilities for over 35 years and has investigated over 500 accidents. He has testified before courts and commissions for over 30 years. His rich and varied knowledge of investigating and litigating utility accidents is shared with seminar participants.

Mr. Clapp is a member (Chair 1984-1993) of the National Electrical Safety Code Committee and a member of the following subcommittees: Interpretations (Past Chair); Strengths and Loadings (Secretary); Clearances (Past Acting Secretary); and Coordination (Chair and Past Secretary). He has served continuously on NESC technical subcommittees since 1971 and has chaired a number of special work-

ing groups. Allen also chairs ANSI Z535.2 Subcommittee on Environmental and Facility Safety Signs.

Allen Clapp is editor of the NESC Handbook published by the Institute of Electrical and Electronics Engineers. He also edits and publishes the DANESC UPDATE™ newsletter and Practical Utility Safety and is a contributor to McGraw-Hill's Standard Handbook for Electrical Engineers.

Richard A. Barber (M) holds a Bachelor of Science degree in electrical engineering from the University of Illinois. He has worked in the electric utility industry since 1986 and has 12 years of engineering, operations, and management experience working for rural electric cooperative and municipal electric systems. Richard presently works for Utility Electrical Consultants, PC, in Raleigh, NC where he is engaged in special projects.